

**VI TELEFILTER****Filter Specification****TFS 76****1/5****1. Measurement condition**

Ambient temperature  $T_A$ : 23 °C  
 Input power level: 0 dBm  
 Terminating impedances at  $f_C$  \*): for input: 56  $\Omega$  // 28,5 pF  
 for output: 50  $\Omega$  // 0 pF

**2. Characteristics**

Remark: Reference level for the relative attenuation  $a_{rel}$  of the **TFS 76** is the minimum of the pass band attenuation  $a_{min}$ . The minimum of the pass band attenuation  $a_{min}$  is defined as the insertion loss  $a_e$ . The centre frequency  $f_C$  is the arithmetic mean value of the upper and lower frequencies at the 1 dB filter attenuation level relative to the insertion loss  $a_e$ . The temperature coefficient of frequency  $Tc_f$  is valid for both the reference frequency  $f_C$  and the frequency response of the filter in the operating temperature range.

Data		typ. value		tolerance / limit
<b>Insertion Loss</b> (Reference level)	$a_e$	20,8	dB	max. 23 dB
<b>Centre Frequency</b> at ambient temperature $f_C$		76,8 MHz $\pm$		75 kHz
<b>Passband</b>	PB			$f_C \pm$ 3,2 MHz
Relative Attenuation	$a_{rel}$			
$f_C$	..... $f_C \pm$ 3,20 MHz	0,35	dB	max. 0,7 dB
$f_C \pm$ 3,20 MHz	..... $f_C \pm$ 3,50 MHz			max. 1 dB
$f_C \pm$ 3,65 MHz	..... $f_C \pm$ 4,85 MHz			min. 1 dB
$f_C \pm$ 4,85 MHz	..... $f_C \pm$ 5,00 MHz	61	dB	min. 51 dB
$f_C -$ 71,8 MHz	..... $f_C -$ 5,00 MHz	65	dB	min. 50 dB
$f_C +$ 5,00 MHz	..... $f_C +$ 123,20 MHz	55	dB	min. 50 dB
<b>Deviation from Linear Phase in PB</b>		0,2	°rms	max. 2 °rms
<b>Group Delay Ripple in PB</b>		60	ns	max. 100 ns
<b>Average Group Delay in PB</b>		1,9	$\mu$ s	max. 3 $\mu$ s
<b>Temperature Coefficient of Frequency</b>		- 76	ppm/K	
<b>Operating Temperature Range</b>				- 0 °C ... + 70 °C
<b>Storage Temperature Range</b>				- 20 °C ... + 80 °C

\*) The terminating impedances depend on parasitics and q-values of matching elements and the board used, and are to be understood as reference values only. Should there be additional questions, do not hesitate to ask for an application note or contact our design team.

generated:

---

checked / approved:

---

**VI TELEFILTER**  
 Potsdamer Straße 18  
 D 14 513 TELTOW / Germany  
 Tel: (+49) 3328 4784-0 / Fax: (+49) 3328 4784-30  
 E-Mail: [ftf@telefilter.com](mailto:ftf@telefilter.com)

**Vectron International, Inc.**  
 267 Lowell Road  
 Hudson, NH 03051 / USA  
 Tel: (603) 598-0070 Fax: (603) 598-0075  
 E-Mail: [vti@vtinh.com](mailto:vti@vtinh.com)

VI TELEFILTER reserves the right to make changes to the product(s) and/or information contained herein without notice. No liability is assumed as a result of their use or application. No rights under any patent accompany the sale of any such product(s) or information.

3. Package

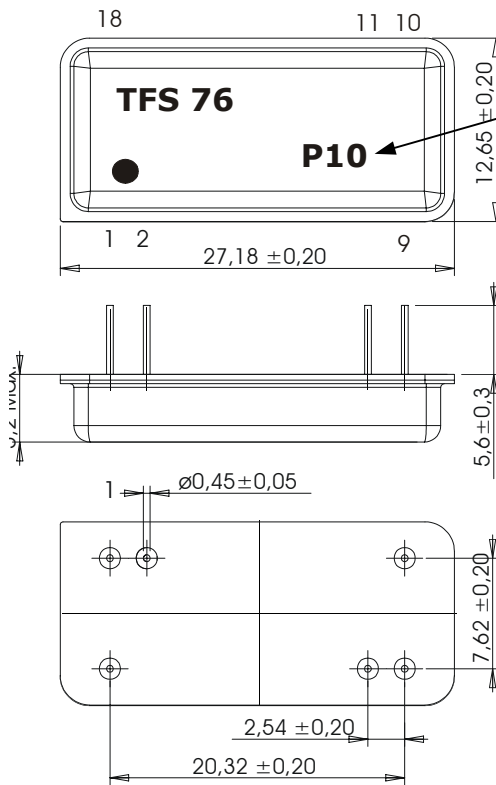

date code:      year + week  
 M                2000  
 N                2001  
 P                2002  
 ....

Pin Configuration

Input: 1  
 Input Return: 18  
 Output: 10  
 Output Return: 9  
 Ground: 2,11

4. 50 Ω matching network :

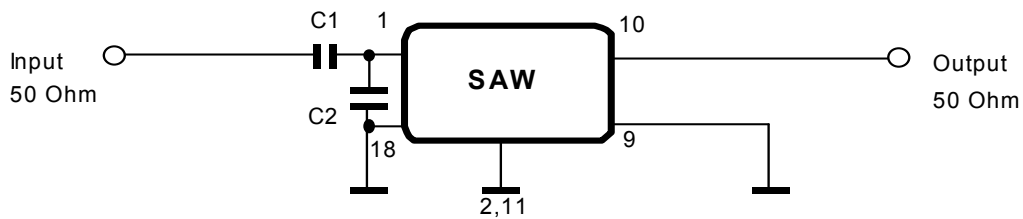

VI TELEFILTER  
 Potsdamer Straße 18  
 D 14 513 TELTOW / Germany  
 Tel: (+49) 3328 4784-0 / Fax: (+49) 3328 4784-30  
 E-Mail: [ftf@telefilter.com](mailto:ftf@telefilter.com)

Vectron International, Inc.  
 267 Lowell Road  
 Hudson, NH 03051 / USA  
 Tel: (603) 598-0070 Fax: (603) 598-0075  
 E-Mail: [vti@vtinh.com](mailto:vti@vtinh.com)

VI TELEFILTER reserves the right to make changes to the product(s) and/or information contained herein without notice. No liability is assumed as a result of their use or application. No rights under any patent accompany the sale of any such product(s) or information.

**5. Stability Characteristics**

After the following tests the filter shall meet the whole specification:

1. Shock: 500g, 18 ms, half sine wave, 3 shocks each plane;  
DIN IEC 68 T2 - 27
2. Vibration: 10 Hz to 500 Hz, 0,35 mm or 5g respectively, 1 octave per min, 10 cycles per plan, 3 plans;  
DIN IEC 68 T2 - 6
3. Change of temperature: -55 °C to 125°C / 30 min. each / 10 cycles  
DIN IEC 68 part 2 – 14 Test N
4. Resistance to solder heat (reflow): reflow possible: twice max.;  
for temperature conditions, please refer to the attached "Air reflow temperature conditions" on page

## 7. Air reflow temperature conditions

1st and 2nd air reflow profile

Name:	pre-heating periods	main-heating periods	peak temperature
Temperature:	150 °C - 170 °C	over 200 °C	255 °C ± 5 °C
Time:	60 sec. - 90 sec.	20 sec. - 25 sec.	

Air reflow profile

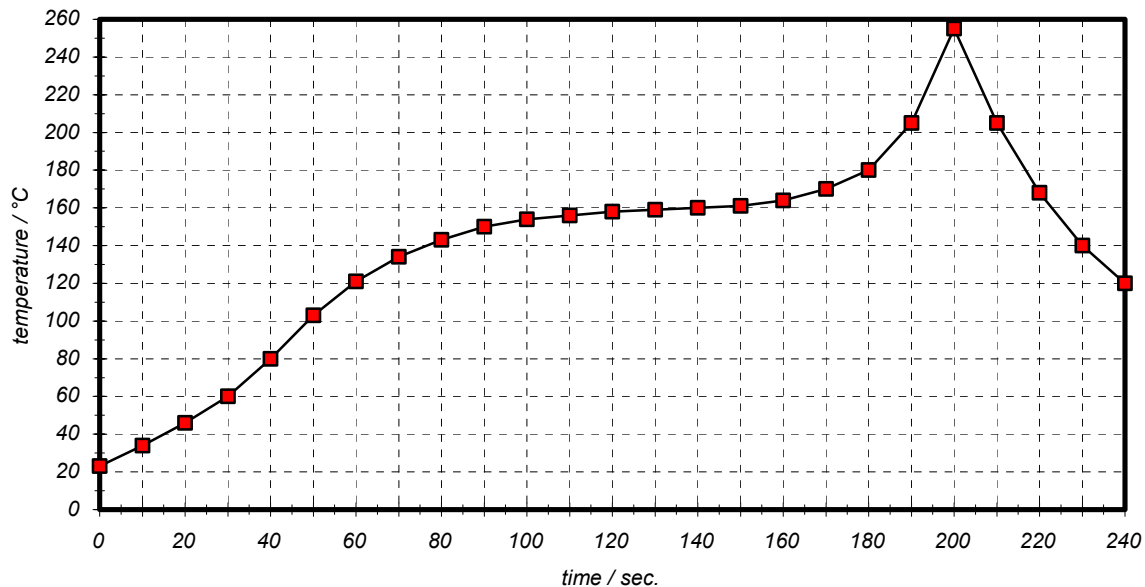

Table for temperature vs. time during the air reflow process

Tolerance of temperatures: ± 5 °C

time / sec.	temperature / °C	time / sec.	temperature / °C
0	23	140	160
10	34	150	161
20	46	160	164
30	60	170	170
40	80	180	180
50	103	190	205
60	121	195	230
70	134	200	255
80	143	205	230
90	150	210	205
100	154	215	180
110	156	220	165
120	158	230	140
130	159	240	120

**8. History**

<b>Version</b>	<b>Reason of Changes</b>	<b>Name</b>	<b>Date</b>
1.0	- generate specification according to customer requirements	Pfeiffer	14.06.2001
1.1	- typical values and terminating impedance added - changing from nominal frequency attenuation related to centre frequency attenuation related - reducing max. insertion loss to 23 dB	Pfeiffer	20.02.2002
1.2	- changing package, matching configuration and terminating impedance	Pfeiffer	01.03.2002