

**VI TELEFILTER****Filter specification****TFS 341 B****1/4****Measurement condition**

Ambient temperature:	25 ± 5	°C
Input power level:	5 ± 2	dBm
Q-value of matching coils: terminating impedances	25	
Source:	630 Ω	-5.2 pF
Load:	620 Ω	-5.0 pF

**Construction and pin connection**

see page 2

**Characteristics**

Remark:

Reference level for the relative attenuation  $a_{rel}$  of the TFS 341 B is the minimum of the pass band attenuation  $a_{min}$ . The minimum of the pass band attenuation  $a_{min}$  is defined as the insertion loss  $a_e$ . The centre frequency  $f_0$  is the arithmetic mean value of the upper and lower frequencies at the 2 dB filter attenuation level relative to the insertion loss  $a_e$ . The given values for the relative attenuation  $a_{rel}$  and for the group delay ripple have to be reached at the frequencies given below also if the centre frequency  $f_0$  is shifted due to the temperature coefficient of frequency  $TC_f$  in the operating temperature range and due to a production tolerance for the centre frequency  $f_0$ .

<b>D a t a</b>		<b>typ. value</b>	<b>limit</b>
<b>Insertion loss</b>	$a_e = a_{min}$	7,5 dB	± 1 dB
<b>Nominal frequency</b>	$f_N$	-	341,0 MHz
<b>Relative attenuation</b>			
$f_N$ .....	$f_N \pm 100$ kHz	-	max. 0,5 dB
$f_N \pm 100$ kHz ...	$f_N \pm 200$ kHz	-	max. 0,8 dB
$f_N \pm 600$ kHz ...	$f_N \pm 1,8$ MHz	-	min. 2,0 dB
$f_N \pm 1,8$ MHz ...	$f_N \pm 2,0$ MHz	-	min. 30 dB
$f_N \pm 2,0$ MHz ...	$f_N \pm 2,4$ MHz	-	min. 30 dB
$f_N \pm 2,4$ MHz ...	$f_N \pm 4,1$ MHz	-	min. 30 dB
$f_N \pm 4,1$ MHz ...	$f_N \pm 4,5$ MHz	-	min. 30 dB
$f_N \pm 4,5$ MHz ...	$f_N \pm 170$ MHz	-	min. 30 dB
1000 MHz ...	1050 MHz	-	min. 35 dB
<b>VSWR ratio</b>			
at source and load impedance, $f_N - 200$ kHz ... $f_N + 200$ kHz		-	max. 2 : 1
at 50 Ω, at $f_N$		<=14 <sup>2)</sup>	
<b>Group delay ripple GD</b>			
$f_N - 200$ kHz ... $f_N + 200$ kHz		-	max. 50 ns
<b>Input power level</b>			
		-	max. + 10 dBm
<b>Permissible DC voltage</b>			
		-	max. 10 V
<b>Operating temperature range</b>		0 °C ... + 85 °C	
<b>Storage temperature range</b>		- 30 °C ... + 85 °C	
<b>Temperature coefficient</b>	TC	- 0,036 ppm/K <sup>2</sup> <sup>1)</sup>	
<b>Frequency inversion temperature</b>	$T_0$	40 °C	-

Note 1) -  $\Delta f$  (Hz) = TC (ppm/K<sup>2</sup>) x (T -  $T_0$ )<sup>2</sup> x  $F_{T_0}$  (MHz)Note 2) Design goal is  $VSWR_{50 \Omega} = 8$ ; limit is  $VSWR_{50 \Omega} = 14$  (typical value)**Generated:** \_\_\_\_\_**Checked / approved:** \_\_\_\_\_

**VI TELEFILTER**  
**Potsdamer Straße 18**  
**D 14 513 TELTOW / Germany**  
**Tel: (+49) 3328 4784-52 / Fax: (+49) 3328 4784-30**  
**E-Mail: tft@telefilter.com**

**Vectron International, Inc.**  
**267 Lowell Road**  
**Hudson, NH 03051 / USA**  
**Tel: (603) 598-0070 Fax: (603) 598-0075**  
**E-Mail: vti@vtinh.com**

VI TELEFILTER reserves the right to make changes to the product(s) and/or information contained herein without notice. No liability is assumed as a result of their use or application. No rights under any patent accompany the sale of any such product(s) or information.

### Construction and pin connection

(All dimensions in mm)

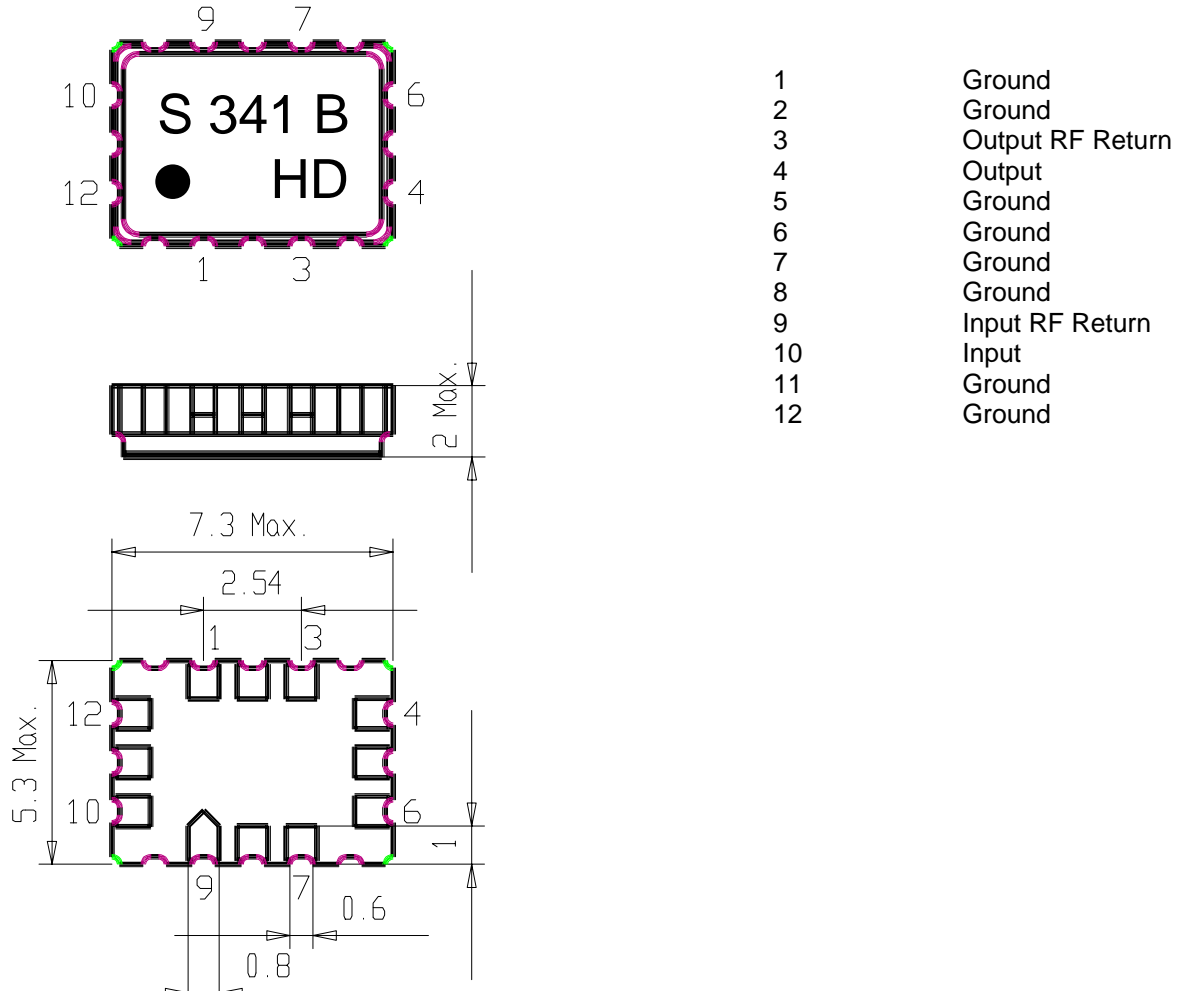

VI TELEFILTER  
 Potsdamer Straße 18  
 D 14 513 TELTOW / Germany  
 Tel: (+49) 3328 4784-52 / Fax: (+49) 3328 4784-30  
 E-Mail: tft@telefilter.com

Vectron International, Inc.  
 267 Lowell Road  
 Hudson, NH 03051 / USA  
 Tel: (603) 598-0070 Fax: (603) 598-0075  
 E-Mail: vti@vtinh.com

**Stability Characteristics:**

After the following tests the filter shall meet the whole specification:

1. Shock: 500g, 18 ms, half sine wave, 3 shocks each plane;  
DIN IEC 68 T2 - 27
2. Vibration: 10 Hz to 500 Hz, 0,35 mm or 5g respectively, 1 octave per min, 10 cycles per plan, 3 plans;  
DIN IEC 68 T2 - 6
3. Damp heat: 25 °C to 55°C / 95% r.H. / 10 cycles  
(cycle) DIN IEC 68 - 2 – 30 Db
4. Resistance to solder heat (reflow): max. 2 times reflow process;  
for temperature conditions refer to the attached "Air reflow temperature conditions" on page 4;

**Packing:**

Tape & Reel: IEC 286 - 3, with exception of value for N and minimum bending radius;  
tape type II, embossed carrier tape with top cover tape on the upper side;

max. pieces of filters per reel: 3000  
Reel of empty components at start: min 300 mm  
Reel of empty components at start including leader: min 500 mm  
Trailer min 300 mm

**Tape (all dimensions in mm)**

W	: 16 ± 0,3
Po	: 4 ± 0,1
Do	: 1,5 + 0,5
D1	: 1,5 + 0,5
E	: 1,75 ± 0,1
F	: 7,5 ± 0,1
G (min)	: 0,75
P2	: 2 ± 0,05
P1	: 8 ± 0,1
D1(min)	: 1,5
Ao	: 5,4 ± 0,1
Bo	: 7,4 ± 0,1

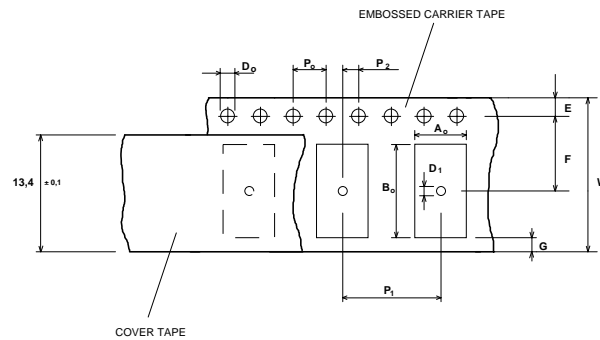
**Reel (all dimensions in mm):**

A	:	330
W1	:	16,4 +2
W2 (max)	:	22,4
N (min)	:	>= 90
C	:	13 ± 0,25

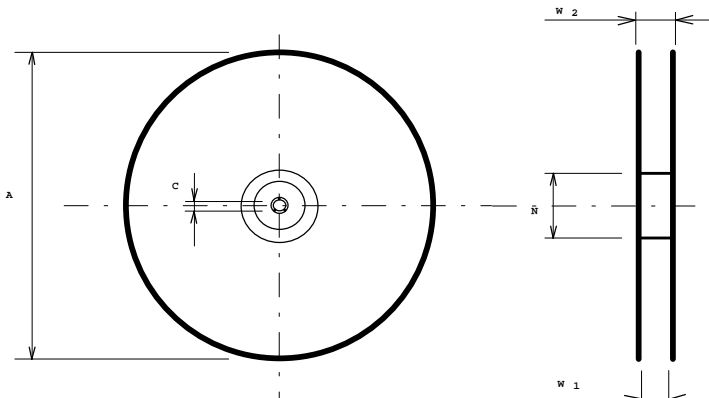

The minimum bending radius is 45 mm. The mounting surface of the filters faces the bottom side of the embossed carrier tape. The marking of the filters is readable if the sprocket holes are on the left side of the tape, i.e. pin 1 identifier is close to the sprocket holes.

**VI TELEFILTER**

Potsdamer Straße 18

D 14 513 TELTOW / Germany

Tel: (+49) 3328 4784-52 / Fax: (+49) 3328 4784-30

E-Mail: tft@telefilter.com

**Vectron International, Inc.**

267 Lowell Road

Hudson, NH 03051 / USA

Tel: (603) 598-0070 Fax: (603) 598-0075

E-Mail: vti@vtinh.com

## Air reflow temperature conditions

## 1st and 2nd air reflow profile

Name:	pre-heating periods	main-heating periods	peak temperature
Temperature:	150 °C - 170 °C	over 200 °C	255 °C ± 5 °C
Time:	60 sec. - 90 sec.	20 sec. - 25 sec.	

## Air reflow profile

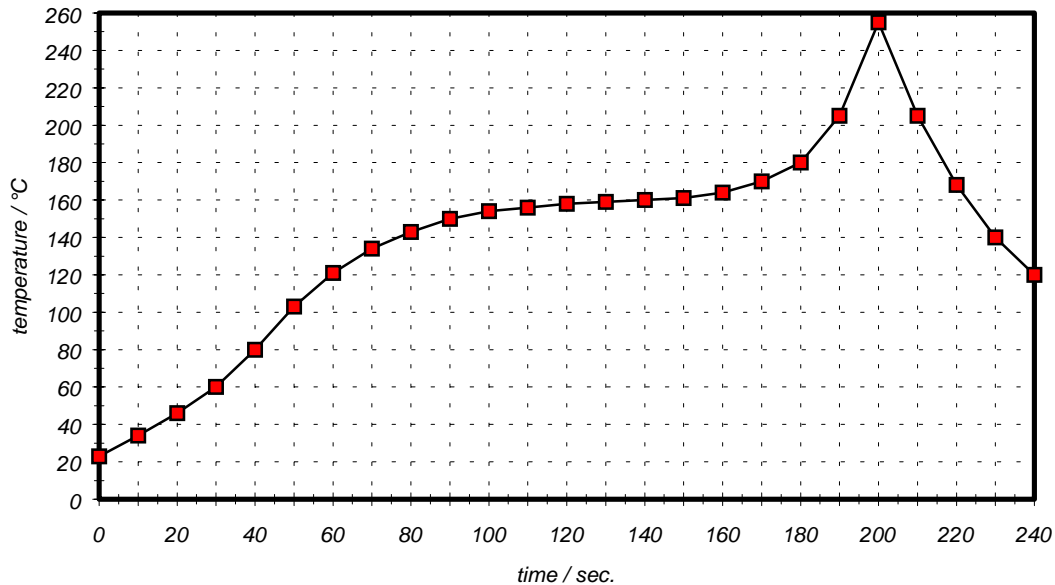

Table for temperature vs. time during the air reflow process

Tolerance of temperatures: ± 5 °C

time / sec.	temperature / °C	time / sec.	temperature / °C
0	23	140	160
10	34	150	161
20	46	160	164
30	60	170	170
40	80	180	180
50	103	190	205
60	121	195	230
70	134	200	255
80	143	205	230
90	150	210	205
100	154	215	180
110	156	220	165
120	158	230	140
130	159	240	120